

SK130XDL		Standard Arm: 2.84 m Bucket: Without, Shoe: 900 mm Counterweight: 1,200 kg												
A	B	1.5 m		3.0 m		4.5 m		6.0 m		7.5 m		At Max. Reach		Radius
		Icon 1	Icon 2	Icon 1	Icon 2	Icon 1	Icon 2	Icon 1	Icon 2	Icon 1	Icon 2	Icon 1	Icon 2	
7.5 m	kg											*1,960	*1,960	4.88 m
6.0 m	kg							*2,410	2,400			*1,670	*1,670	6.26 m
4.5 m	kg					*3,180	*3,180	*3,070	2,380			*1,580	*1,580	7.05 m
3.0 m	kg			*5,830	*5,830	*4,100	3,550	*3,450	2,260			*1,590	1,560	7.46 m
1.5 m	kg			*7,110	5,880	*5,140	3,240	3,380	2,130	*1,940	*1,510	*1,680	1,490	7.54 m
G.L.	kg			*6,590	5,560	5,030	3,040	3,270	2,030			*1,880	1,530	7.31 m
-1.5 m	kg	*5,000	*5,000	*9,090	5,530	4,960	2,970	3,230	1,990			*2,290	1,710	6.74 m
-3.0 m	kg	*8,270	*8,270	*7,920	5,660	5,010	3,030					*3,260	2,200	5.71 m

SK130XDL		Standard Arm: 2.84 m Bucket: Without, Shoe: 700 mm Counterweight: 1,200 kg												
A	B	1.5 m		3.0 m		4.5 m		6.0 m		7.5 m		At Max. Reach		Radius
		Icon 1	Icon 2	Icon 1	Icon 2	Icon 1	Icon 2	Icon 1	Icon 2	Icon 1	Icon 2	Icon 1	Icon 2	
7.5 m	kg											*1,970	*1,970	4.84 m
6.0 m	kg							*2,360	2,310			*1,670	*1,670	6.24 m
4.5 m	kg					*3,170	*3,170	*3,070	2,280			*1,580	*1,580	7.04 m
3.0 m	kg			*5,760	*5,760	*4,080	3,420	3,390	2,170			*1,590	1,490	7.46 m
1.5 m	kg			*7,220	5,650	5,060	3,110	3,240	2,040	*1,950	1,440	*1,680	1,420	7.55 m
G.L.	kg			*6,550	5,310	4,830	2,910	3,130	1,940			*1,880	1,450	7.32 m
-1.5 m	kg	*4,940	*4,940	*9,110	5,280	4,740	2,840	3,090	1,900			*2,270	1,620	6.76 m
-3.0 m	kg	*8,180	*8,180	*7,960	5,410	4,800	2,890					*3,220	2,080	5.74 m

- Notes:**
- Do not attempt to lift or hold any load that is greater than these lift capacities at their specified lift point radius and heights. Weight of all accessories must be deducted from the above lift capacities.
 - Lift capacities are based on machine standing on level, firm, and uniform ground. User must make allowance for job conditions such as soft or uneven ground, out of level conditions, side loads, sudden stopping of loads, hazardous conditions, experience of personnel, etc.
 - Arm top defined as lift point.
 - The above lift capacities are in compliance with ISO 10567. They do not exceed 87% of hydraulic lift capacity or 75% of tipping load. Lift capacities marked with an asterisk (*) are limited by hydraulic capacity rather than tipping load.
 - Operator should be fully acquainted with the Operator's and Maintenance Instructions before operating this machine. Rules for safe operation of equipment should be adhered to at all times.
 - Lift capacities apply to only machine originally manufactured and normally equipped by KOBELCO CONSTRUCTION MACHINERY CO., LTD.

STANDARD EQUIPMENT

- | | | |
|--|---|--|
| <p>ENGINE</p> <ul style="list-style-type: none"> Engine, MITSUBISHI D04FR-74KW, diesel engine with turbocharger and intercooler Automatic engine deceleration Auto Idle Stop (AIS) Batteries (2 x 12V - 100Ah) Starting motor (24V - 5 kW), 50 amp alternator Automatic engine shut-down for low engine oil pressure Engine oil pan drain cock Double element air cleaner <p>CONTROL</p> <ul style="list-style-type: none"> Working mode selector (H-mode, S-mode and ECO-mode) | <p>SWING SYSTEM & TRAVEL SYSTEM</p> <ul style="list-style-type: none"> Swing rebound prevention system Straight propel system Two-speed travel with automatic shift down Sealed & lubricated track links Grease-type track adjusters Automatic swing brake <p>HYDRAULIC</p> <ul style="list-style-type: none"> Arm regeneration system Aluminum hydraulic oil cooler <p>MIRRORS & LIGHTS</p> <ul style="list-style-type: none"> Two rear view mirrors Two front working lights (one for boom, and one for right storage box) | <p>CAB & CONTROL</p> <ul style="list-style-type: none"> Two control levers, pilot-operated Horn, electric Cab light (interior) Luggage tray Large cup holder Detachable two-piece floor mat Headrest Handrails Intermittent windshield wiper with double-spray washer Skylight Tinted safety glass Pull-up type front window and removable lower front window Easy-to-read multi-display color monitor Automatic air conditioner Emergency escape hammer KOMEXS |
|--|---|--|

OPTIONAL EQUIPMENT

- | | |
|---|---|
| <ul style="list-style-type: none"> Additional track guide Two cab lights N & B piping Wide range of buckets | <ul style="list-style-type: none"> Various optional arms Wide range of shoes Logging guard |
|---|---|

Note: Standard and optional equipment may vary. Consult your KOBELCO dealer for specifics.

Note: This catalog may contain attachments and optional equipment that are not available in your area. And it may contain photographs of machines with specifications that differ from those of machines sold in your areas. Please consult your nearest KOBELCO distributor for those items you require. Specialist equipment is needed to use this machine in demolition work. Before using it please contact your KOBELCO dealer. Due to our policy of continuous product improvements all designs and specifications are subject to change without advance notice. Copyright by **KOBELCO CONSTRUCTION MACHINERY CO., LTD.** No part of this catalog may be reproduced in any manner without notice.

KOBELCO CONSTRUCTION MACHINERY CO., LTD.

5-15, Kitashinagawa 5-chome, Shinagawa-ku, Tokyo 141-8626 JAPAN
 Tel: +81 (0) 3-5789-2146 Fax: +81 (0) 3-5789-2135
 www.kobelcocm-global.com

Inquiries To:



Bound for mountains and forests all over the world.



Kobelco's innovation has created earth-friendly construction machinery for use on all manner of sites all over the world. Their power, durability and overwhelming fuel efficiency brings high productivity to any project. The SK130XDL-10 boasts low fuel consumption while achieving even greater efficiency. Its durability makes it well-suited for forestry work, and it's even easier to maintain. With a degree of performance that meets even the highest expectations, it can tough-out the harshest of worksites. With its focus on the future of our global environment, Kobelco is committed to further improving work efficiency and reducing life-cycle costs as it offers new, cutting-edge value.



SK130XDL

Impressive power and unrivalled workability improve performance.



Get More Done Faster with Superior Operability

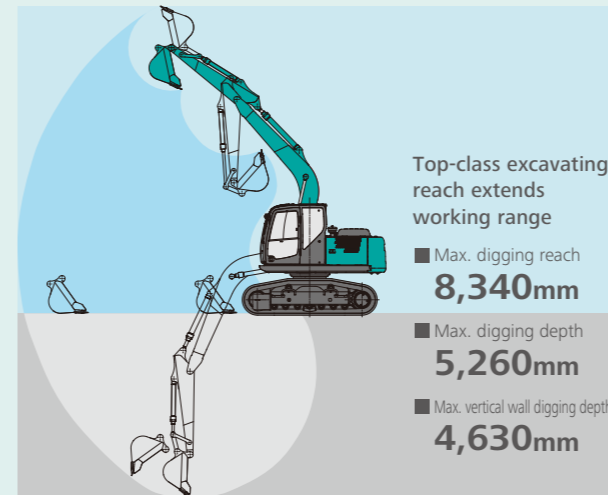

*1 Values are for STD arm (2.38m)
*2 Without including height of shoe

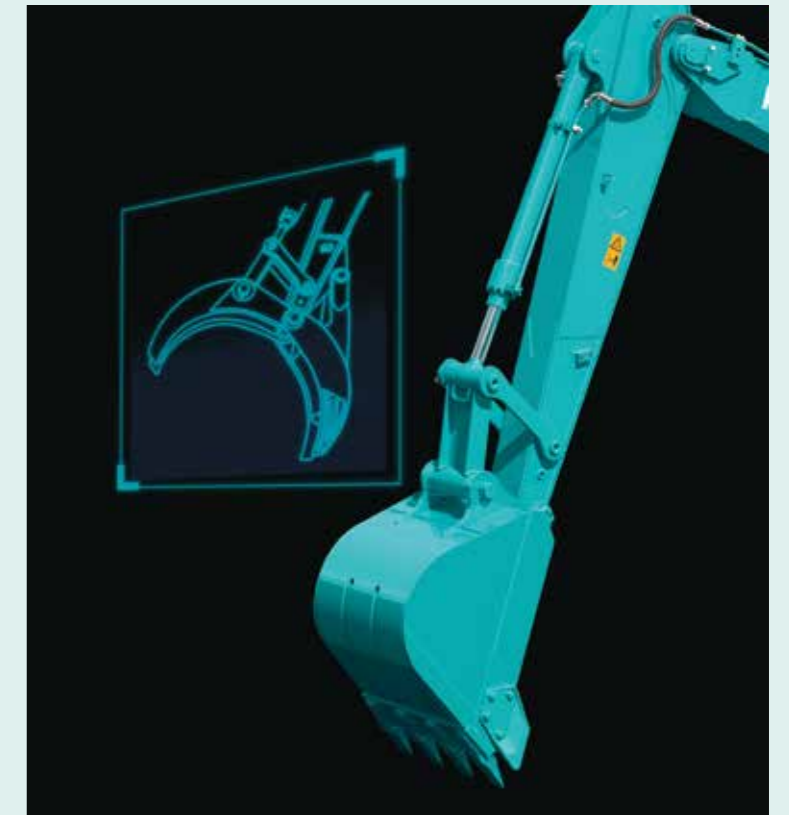

Grapple installation

The tip attachment can be changed to a grapple or other equipment according to the type of task, making operation on a wide variety of sites possible.

Improved Workability

Hydraulic pressure control has been updated through the use of new components and an improved hydraulic pressure system. More powerful and easier to use, it achieves a high level of operability and efficiency.

Powerful arm operation + climbing ability NEW

Driving power doesn't decline even when doing work with attachments while ascending slopes. Powerfully climb steep slopes even while operating the arm.

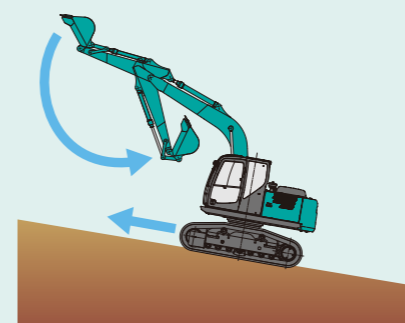

Improved lifting and turning performance on slopes NEW

Control of hydraulic balance between attachments and swivel parts has been optimized. Even if the boom is engaged while turning, such as when collecting trees on a slope, the turning stays smooth.

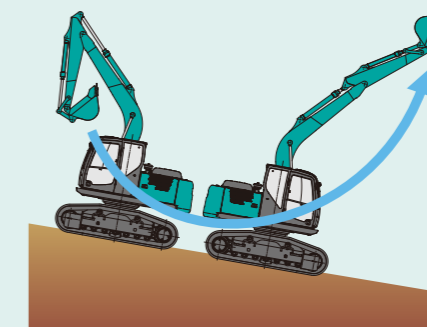

Speedy combined operations

Combined attachment operations, such as horizontal pulling to operate the boom and arm at the same time, are also nimble and smooth, making it possible to work faster.

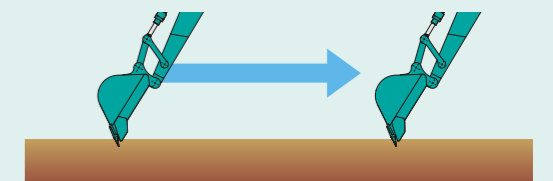

Independent driving function NEW

The circuits of the attachment and the running gear are separated, so whether or not there are attachment operations has no effect on driving. Running speed can be maintained even while felled trees are being collected.

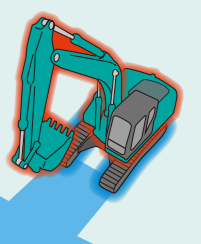

High durability even in the harshest of environments.



Upper Structure

Cooling System **NEW**



The oil cooler has been changed from a two-layer to a one-layer type. This prevents dust from collecting in the gaps, helping to maintain the cooling function. In addition, the condenser in front of the radiator can be opened and closed, and there is a lever on the condenser bracket, making the radiator much easier to clean.

Logging Guard (Option) **NEW**

The logging guard has also been newly designed to coincide with the adoption of the ROPS structure cab that protects the operator in the event of a fall. The new pre-air cleaner also has a guard, with an optional cab light that can be installed inside. In addition, the shape of the bumper corner has been changed so that it fits within the rear turning radius, making it easier to turn even in narrow spaces.

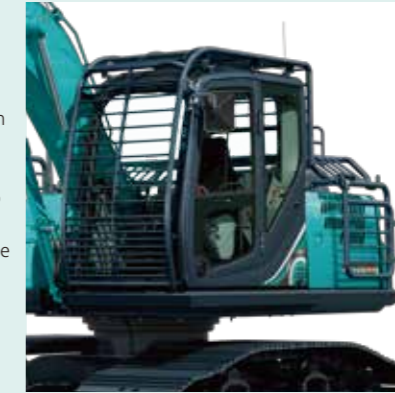

Attachment/Equipment

Reinforced Attachments

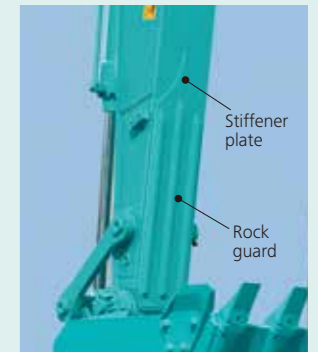

There is a new long arm. Additionally, lock guard reinforcement can now be attached to the tip. The shape of the lower plate has been optimized for logging work, and the arm strength is enhanced.

Side Deck Bumpers



Side deck bumpers are fitted to protect power plant and cab, and also simplify mounting of other (optional) protective equipment.

Plenty of Clearance



Increased clearance between upper frame and top of crawlers prevents wood debris building up and impeding travel.

Reinforced Undercover



Reinforced undercover protects the piping and other components from damage caused by accidental contact with branches, debris and other obstacles.

Travel System

Double Support Upper Rollers

Improved support provided by new design for upper rollers reduces shaking and jolting of crawler shoes for smoother travel.



Reinforced Guide Frame

Reinforced guide frame prevents deformation caused by impact or encroaching of loose stones.



One Class Higher Travel Motor

The greater power of the travel motor gives rugged, reliable traction. The SK130XDL provides the powerful travel needed to pull log sleds or work in wetlands, on rough terrain, in woods or on farms.



■ Top-class drawbar pulling force: **196kN**

Single Grouser Shoes

Crawlers have single grouser shoes with 58 mm lugs, instead of the usual triple grouser shoes, to stop mud clogging between the grousers. Travel is firm and fast, even across wet, muddy ground.



Low Ground Pressure

Low ground pressure is assured by oversized crawler length and width, for smoother and easier transfer and travel.

■ Ground pressure: **26.0kPa**

*Values are for STD arm (2.38m) and 900mm single grouser shoes.

Wide Shoes Ensure Plenty of Traction

You can count on smooth and dependable travel with longer crawlers and wider shoes that are usually used on machines the next class up.

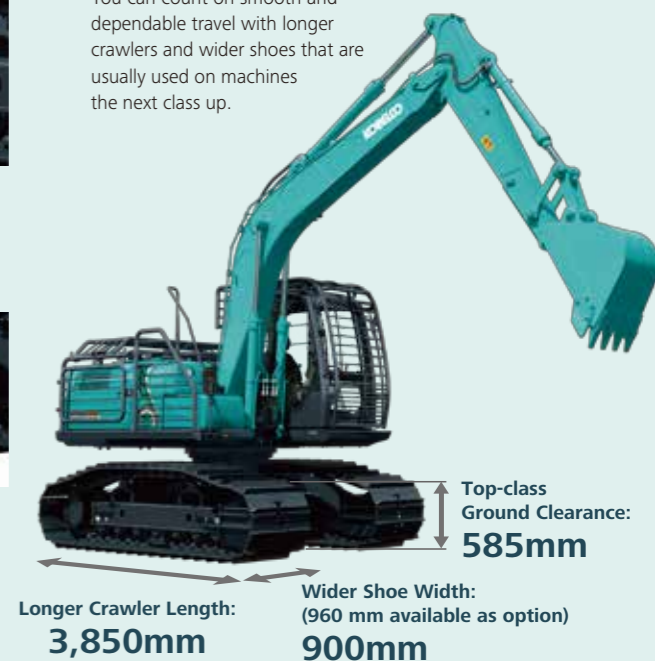

We're always pursuing fuel efficiency.

Efficient maintenance to sustain high performance.

Reduced fuel consumption in ECO-mode

ECO-mode: Engineered for Economy NEW

Kobelco's ECO-mode maximizes the operating efficiency of the engine and other components to achieve much greater fuel efficiency. Just press a button to choose the operation mode best suited to the task at hand and the working conditions.

Optimal operation with three modes

H H-mode ••• Maximum power for maximum productivity on your toughest jobs

S S-mode ••• Ideal balance of productivity and fuel efficiency for a range of urban engineering projects

E ECO-mode ••• Minimum fuel consumption for utility projects and other work that demands precision

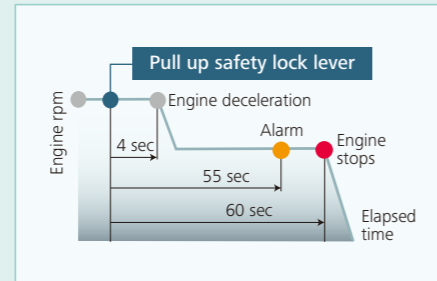

AIS (Auto Idle Stop)

If the safety lock lever is lifted up, the engine will stop automatically. This eliminates wasteful idling during standby, saving fuel and reducing CO₂ emissions as well.

Hydraulic system engineered to reduce energy loss

Kobelco's proprietary hydraulic systems offer hydraulic line positioning that reduces friction resistance and valves designed for higher efficiency, minimizing energy loss throughout the system.

Always and forever. Yesterday, today, and tomorrow. We're obsessed with fuel efficiency

Our new ECO-mode is 20% more fuel efficient than the SK130HDL-8B H-mode.

Operator-friendly Features Include Controls that Are Easy to See, Easy to Use



Multi-Display in Color NEW

Brilliant colors and graphic displays are easy to recognize on the LCD multi-display in the console. The display shows fuel consumption, maintenance intervals, and more.

- 1 Analog gauge provides an intuitive reading of fuel level and engine water temperature
- 2 Green indicator light shows low fuel consumption during operation
- 3 Fuel consumption/Switch indicator for rear camera images
- 4 Digging mode switch
- 5 Monitor display switch

One-Touch Attachment Mode Switch

A simple touch of a button, switches the hydraulic circuit and flow amount to match attachment changes. Icons help the operator to confirm the proper configuration at a glance.

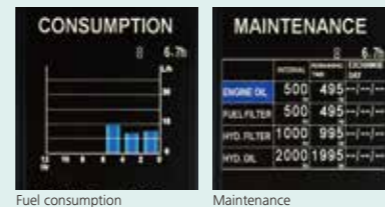

Fuel consumption Maintenance

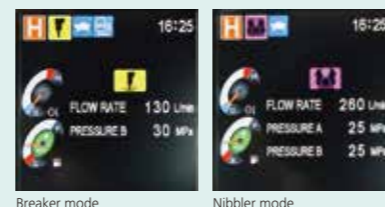

Breaker mode Nibbler mode

Compatible with Biofuel

Biofuel may be used with Kobelco machinery, reducing environmental impact and supporting business. *For more information about using biofuels, please contact the nearest dealer.

Maintenance Work, Daily Checks, Etc., Can Be Done from Ground Level

The layout allows for easy access from the ground for many daily checks and regular maintenance tasks.



Left side Simple layout for easy access to radiator and cooling system elements

Right side



Pre-filter (with built-in water separator) Main fuel filter Third filter Pilot Line Filter

- 1 Pre-filter (with built-in water separator)
- 2 Pilot Line Filter
- 3 Main fuel filter
- 4 Third filter

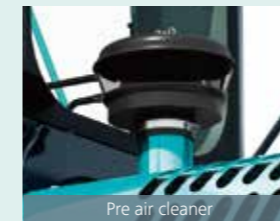

Pre air cleaner

An enlarged cartridge-type pilot filter simplifies maintenance.

Easy Cleaning

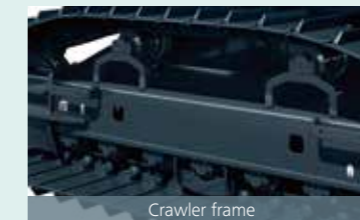

Crawler frame Special crawler frame design for easy mud removal cleaning.

More Efficient Maintenance Inside the Cab



Air conditioner filters Internal and external air conditioner filters can be easily removed without tools for cleaning.



Detachable two-piece floor mat Detachable two-piece floor mat with handles for easy removal. A floor drain is located under floor mat.



Floor mat with raised edges Floor mat's raised edges help keep the cab floor free of mud, simplify cleaning.

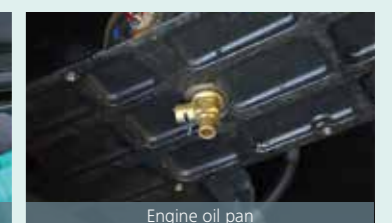

Engine oil pan Engine oil pan equipped with drain valve.



Examples of displaying maintenance information

Machine Information Display Function

- Displays only the maintenance information that's needed, when it's needed
- Self-diagnostic function provides early-warning detection and display of electrical system malfunctions
- Service-diagnostic function makes it easier to check the status of the machine
- Record function of previous breakdowns including irregular and transient malfunction

Long-life hydraulic oil: **2,000** hours

Long-Interval Maintenance

Long-life hydraulic oil reduces cost and labor.

Replacement cycle: **1,000** hours

Highly Durable Premium-fine Filter

The high-capacity hydraulic oil filter incorporates glass fiber with superior cleaning power and durability.



Comfortable Cab Is Now Safer than Ever.

A work environment that is quieter and more comfortable. A cab that puts the operator first is key to improved safety.



*Prevention bar shall be equipped on the right side window and the armrest will not be installed for this model.



*Prevention bar shall be equipped on the right side window.

Comfort

Super-Airtight Cab



The high level of air-tightness keeps dust out of the cab.

Quiet Inside

The high level of air-tightness ensures a quiet, comfortable cabin interior.

Low Vibration

Coil springs absorb small vibrations, and high suspension mounts filled with silicone oil reduce heavy vibration. The long stroke achieved by this system provides excellent protection from vibration.

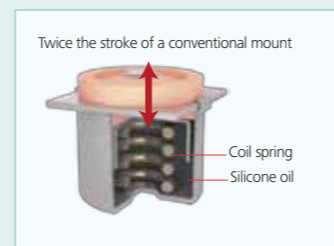

Anti-theft measures

Theft-prevention brackets have been installed on the ECU, mechatronics, and cluster panels. Their structure makes removal very difficult.



Broad View Liberates the Operator

The front window features one large piece of glass without a center pillar on the right side for a wide, unobstructed view.

Air Conditioner Louvers behind the Seat NEW

The large air-conditioner has louvers on the back pillars that blow from behind and to the right and left of the operator's seat. They can be adjusted to put a direct flow of cool/warm air on the operator, which means a more comfortable operating environment.



More Comfortable Seat Means Higher Productivity

Seat recliner can be pushed back flat and double slides allow adjustment for optimum comfort.



*Product image for illustration purposes only.

Large Cab Is Easy to Get in and Out of

The expanded cab provides plenty of room for a large door, more headroom and smoother entry and exit.



*Prevention bar shall be equipped on the right side window and the armrest will not be installed for this model.

Interior Equipment Adds to Comfort and Convenience



Spacious storage tray



Large cup holder

Safety

ROPS Cab

ROPS (Roll-Over-Protective Structure)-compliant cab clears ISO standards (ISO-12117-2: 2008) and ensures greater safety for the operator should the machine tip over.



Expanded Field of View for Greater Safety



Rearview mirrors left and right

Greater safety assured by rearview mirrors on left and right.

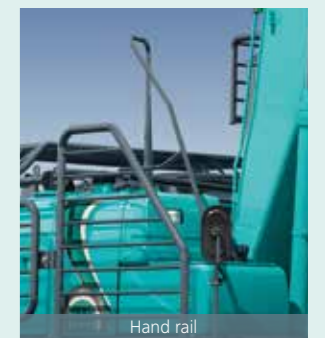

Hand rail



Prevention bar for leaning out of window

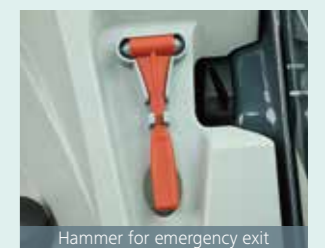

Hammer for emergency exit



Remote Monitoring for Peace of Mind

KOMEXS uses satellite communication and internet to relay data, and therefore can be deployed in areas where other forms of communication are difficult. When a hydraulic excavator is fitted with this system, data on the machine's operation, such as operating hours, location, fuel consumption, and maintenance status can be obtained remotely.

Direct Access to Operational Status

Location Data

• Accurate location data can be obtained even from sites where communications are difficult.

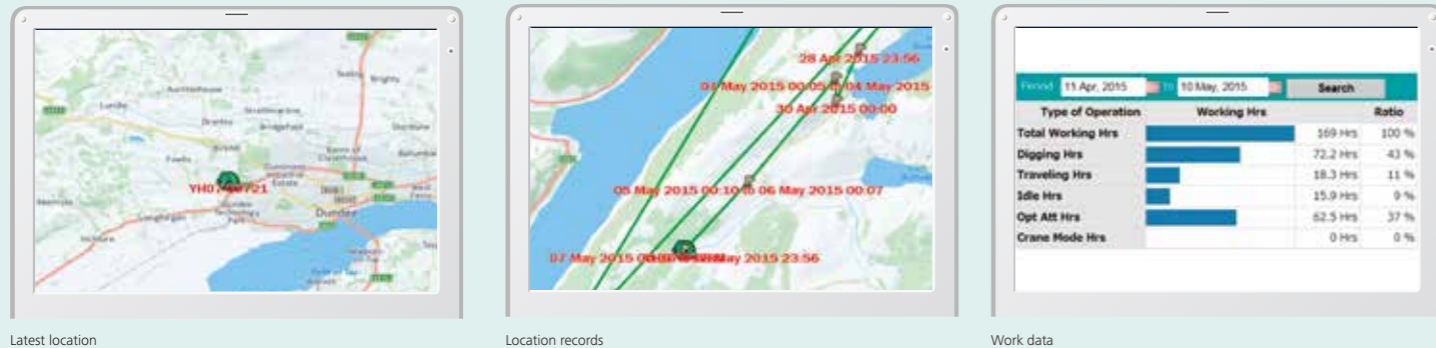

Operating Hours

- A comparison of operating times of machines at multiple locations shows which locations are busier and more profitable.
- Operating hours on site can be accurately recorded, for running time calculations needed for rental machines, etc.

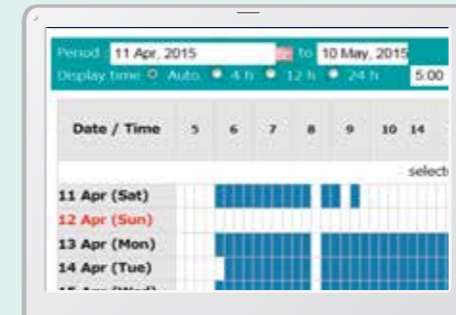

Daily report

Fuel Consumption Data

- Data on fuel consumption and idling times can be used to indicate improvements in fuel consumption.

Work mode	Working Hrs	Total Fuel Consumption
H mode	2:06	24.5 L
S mode	0:00	0.0 L
E mode	169:19	1489.7 L
TOTAL	171:25	1514.2 L

Fuel consumption

Graph of Work Content

- The graph shows how working hours are divided among different operating categories, including digging, idling, travelling and optional operations.



Work status

Maintenance Data and Warning Alerts

Machine Maintenance Data

- Provides maintenance status of separate machines operating at multiple sites.
- Maintenance data is also relayed to KOBELCO service personnel, for more efficient planning of periodic servicing.

Model	Serial No.	Hour Meter	Engine Oil
SK135SRLC-3/SK140SRL	YH07-09721	734 Hr	434
SK135SRLC-3/SK140SRL	YH07-09789	73 Hr	429
SK210LC-9	YQ13-10454	960 Hr	58
SK210LC-9	YQ13-10481	549 Hr	498
SK75SR-	YT08-30174		

Maintenance

Warning Alerts

- This system gives an alert if an anomaly is sensed, preventing damage that could result in machine downtime.

Alarm Information Can Be Received via E-mail

- Alarm information or maintenance notice can be received via e-mail, using a computer or a mobile device.



Alarm messages can be received on a mobile device.

Daily/Monthly Reports

- Operational data downloaded onto a computer helps in formulating daily and monthly reports.

Security System

Engine Start Alarm

- The system can be set up with an alarm if the machine is operated outside designated time.



Engine start alarm outside prescribed work time

Area Alarm

- It can be set up with an alarm if the machine is moved out of its designated area to another location.



Alarm for outside of reset area



Engine

Model	MITSUBISHI D04FR-74kW
Type	Water-cooled, 4 cycle 4 cylinder direct injection type diesel engine with intercooler turbo-charger
No. of cylinders	4
Bore and stroke	102 mm x 130 mm
Displacement	4.249 L
Rated power output	69.2 kW / 2,000 min ⁻¹ (ISO 9249: with fan) 74 kW / 2,000 min ⁻¹ (ISO 14396: without fan)
Max. torque	359 N*m / 1,600 min ⁻¹ (ISO 9249: with fan) 375 N*m / 1,600 min ⁻¹ (ISO 14396: without fan)

Hydraulic System

Pump	
Type	Two variable displacement pumps + one gear pump
Max. discharge flow	2 x 130 L/min, 1 x 20 L/min
Relief valve setting	
Boom, arm and bucket	34.3 MPa (350 kgf/cm ²)
Travel circuit	34.3 MPa (350 kgf/cm ²)
Swing circuit	28.0 MPa (296 kgf/cm ²)
Control circuit	5.0 MPa (50 kgf/cm ²)
Pilot control pump	Gear type
Main control valve	12-spool
Oil cooler	Air cooled type

Swing System

Swing motor	Axial piston motor
Brake	Hydraulic; locking automatically when the swing control lever is in neutral position
Parking brake	Oil disc brake, hydraulic operated automatically
Swing speed	11 min ⁻¹ {rpm}
Tail swing radius	2,180 mm
Min. front swing radius	2,640 mm

Attachments

Backhoe bucket and combination

Type	Backhoe bucket	
Bucket capacity	ISO heaped	m ³ 0.45
	ISO Struck	m ³ 0.35
Opening width	With side cutter	mm 915
	Without side cutter	mm 815
No. of teeth		4
Bucket weight		kg 360
Combination	2.38 m arm	◎
	2.38 m arm (with rock guard)	○
	2.84 m arm	○
	2.84 m arm (with rock guard)	○

◎ Standard combination ○ General operation

Operating Weight & Ground Pressure

In standard trim, with standard boom, 2.38 m arm, and 0.45 m³ ISO heaped bucket

Shaped	Grouser shoes (even height)			
Shoe width	mm 700 (triple)	900 (single)	900 (triple)	960 (single)
Overall width of crawler	mm 2,740	2,940	2,940	3,000
Ground pressure	kPa 32	26	26	24
Operating weight	kg 15,000	15,500	15,400	15,700



Travel System

Travel motors	2 x axial-piston, two-step motors
Travel brakes	Hydraulic brake per motor
Parking brakes	Oil disc brake per motor
Travel shoes	42 each side
Travel speed	4.8 / 2.4 km/h
Drawbar pulling force	196 kN (20,000kgf) SAE J 1309
Gradeability	70 % {35°}

Cab & Control

Cab	
All-weather, sound-suppressed steel cab mounted on the high suspension mounts filled with silicone oil and equipped with a heavy, insulated floor mat.	
Control	
Two hand levers and two foot pedals for travel	
Two hand levers for excavating and swing	
Electric rotary-type engine throttle	

Boom, Arm & Bucket

Boom cylinders	100 mm x 1,092 mm
Arm cylinder	115 mm x 1,116 mm
Bucket cylinder	95 mm x 903 mm

Refilling Capacities & Lubrications

Fuel tank	271 L
Cooling system	16 L
Engine oil	18.5 L
Travel reduction gear	2 x 4.5 L
Swing reduction gear	1.65 L
Hydraulic oil tank	104 L tank oil level
	160 L hydraulic system



Working Ranges

Range	4.68 m	
	2.38m	2.84m
a- Max. digging reach	8.34	8.78
b- Max. digging reach at ground level	8.14	8.59
c- Max. digging depth	5.26	5.72
d- Max. digging height	8.76	9.07
e- Max. dumping clearance	6.35	6.65
f- Min. dumping clearance	2.50	2.06
g- Max. vertical wall digging depth	4.63	5.10
h- Min. swing radius	2.64	2.80
i- Horizontal digging stroke at ground level	4.23	4.71
j- Digging depth for 2.4 m (8') flat bottom	5.03	5.53
Bucket capacity ISO heaped m ³	0.45	0.45

Digging Force (ISO 6015)	
Arm length	2.38m 2.84m
Bucket digging force	90.4 90.4
Arm crowding force	64.1 58.1

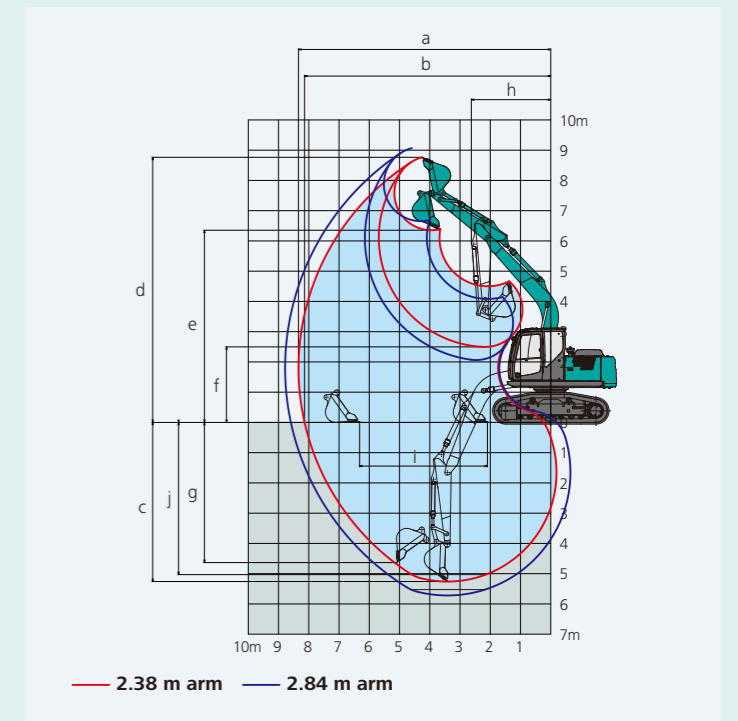

Dimensions

Arm length	2.38m	2.84m
A Overall length	7,700	7,820
B Overall height (to top of boom)	2,760	3,150
C Overall width of crawler	2,940	2,940
D Overall height (to top of cab)	3,170	3,170
E Ground clearance of rear end*	1,120	1,120
F Ground clearance*	585	585

Unit: mm	
G Tail swing radius	2,180 2,180
G' Distance from center of swing to rear end	2,180 2,180
H Tumbler distance	2,990 2,990
I Overall length of crawler	3,850 3,850
J Track gauge	2,040 2,040
K Shoe width	900 900
L Overall width of upperstructure	2,750 2,750

*Without including height of shoe lug

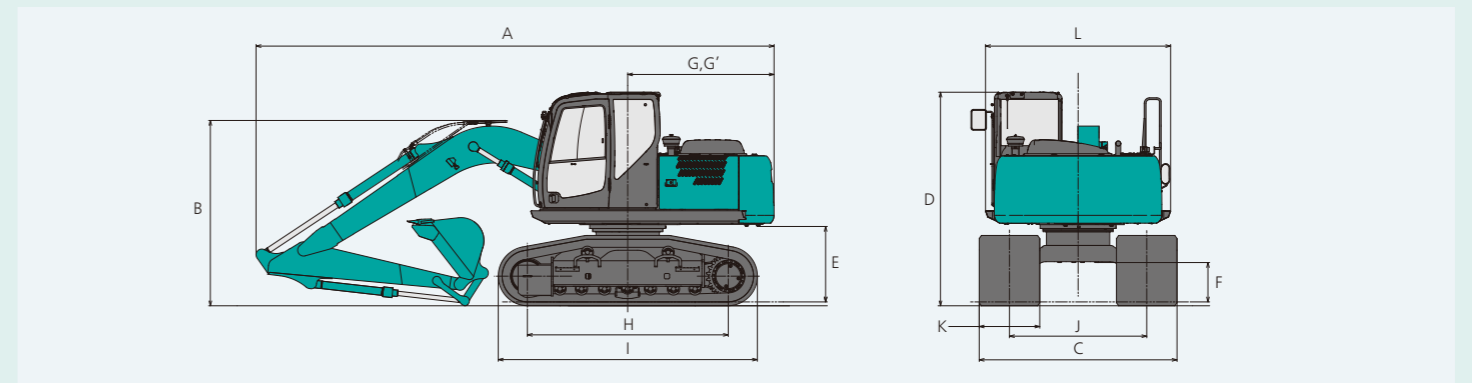

Lift Capacities

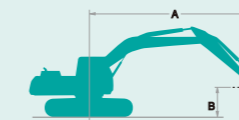

Rating over front

Rating over side or 360 degrees

A: Reach from swing centerline to arm top
B: Arm top height above/below ground
C: Lift point
Bucket: Without bucket
Relief valve setting: 34.3 MPa (350 kgf/cm²)

SK130XDL	Standard Arm: 2.38 m Bucket: Without, Shoe: 900 mm Counterweight: 1,200 kg											
	1.5 m		3.0 m		4.5 m		6.0 m		At Max. Reach			
B	Rating over front	Rating over side or 360 degrees	Rating over front	Rating over side or 360 degrees	Rating over front	Rating over side or 360 degrees	Rating over front	Rating over side or 360 degrees	Rating over front	Rating over side or 360 degrees	Radius	
7.5 m	kg								*2,150	*2,150	4.14 m	
6.0 m	kg				*3,210	*3,210			*1,770	*1,770	5.71 m	
4.5 m	kg				*3,620	*3,620	*3,400	2,350	*1,670	*1,670	6.58 m	
3.0 m	kg		*6,830	6,500	*4,520	3,500	3,510	2,260	*1,680	*1,680	7.01 m	
1.5 m	kg		*5,220	*5,220	5,230	3,230	3,390	2,140	*1,790	1,670	7.10 m	
G.L.	kg		*6,600	5,600	5,050	3,070	3,300	2,060	*2,030	1,720	6.86 m	
-1.5 m	kg	*5,870	*5,870	*8,830	5,640	5,020	3,040	3,300	2,060	*2,550	1,960	6.24 m
-3.0 m	kg	*9,870	*9,870	*7,310	5,810	*4,930	3,130		*3,970	2,650	5.10 m	